



PA | PAC | PAD series

piston pumps

fixed displacement in-line design

ADVANTAGES

- ▶ *Of unique design, the PA, PAC and PAD pumps offer a robust solution with **long service life** for high pressure requirements in truck hydraulics.*
- ▶ *Relatively insensitive to contamination, these pumps are particularly **well suited to the harshest environments**.*
- ▶ *The design means the pumps can rotate either clockwise or counter-clockwise **without any user intervention**.*
- ▶ *Like all truck pumps designed by HYDRO LEDUC, this range is fitted with the **latest innovation in terms of sealing**:*
 - *Front of pump fitted with two shaft seals: externally, a seal capable of resisting the high temperatures of the gearbox, and internally, a seal adapted to the hydraulic requirements.*
 - *A transparent flexible tube fitted between the two seals, to protect these seals from dirt from the road, and from high pressure water jet during washing of vehicle etc...*



The PA, PAC, PAD pump series comprises three ranges, all designed for truck applications at working pressures up to 5800 psi (400 bar) continuous and 7252 psi (500 bar) peak.

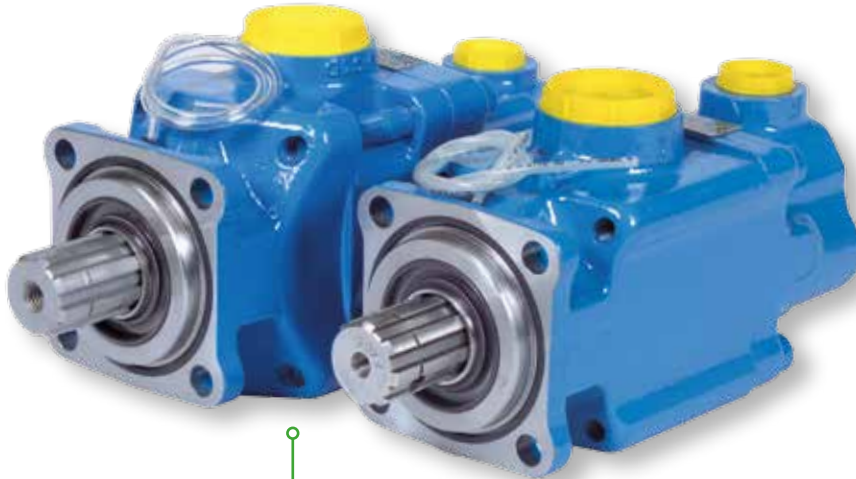

► PA pumps

- single flow from 25 to 114 cc/rev
- twin-flow from 2x32 to 2x75 cc/rev
- two different flows: 75 - 40 cc/rev

► PAC pumps

Series offering the most compact size envelope:

- single flow from 25 to 80 cc/rev
- twin-flow from 2x25 to 2x40 cc/rev



► PAD pumps

Two-flow pumps, with 10 pistons, thus offering optimal flow regularity within reduced size envelope:

- twin-flow: 2x32 to 2x67 cc/rev
- two different flows: 55-33 et 67 - 40 cc/rev

PA | PAC | PAD - Dimensions

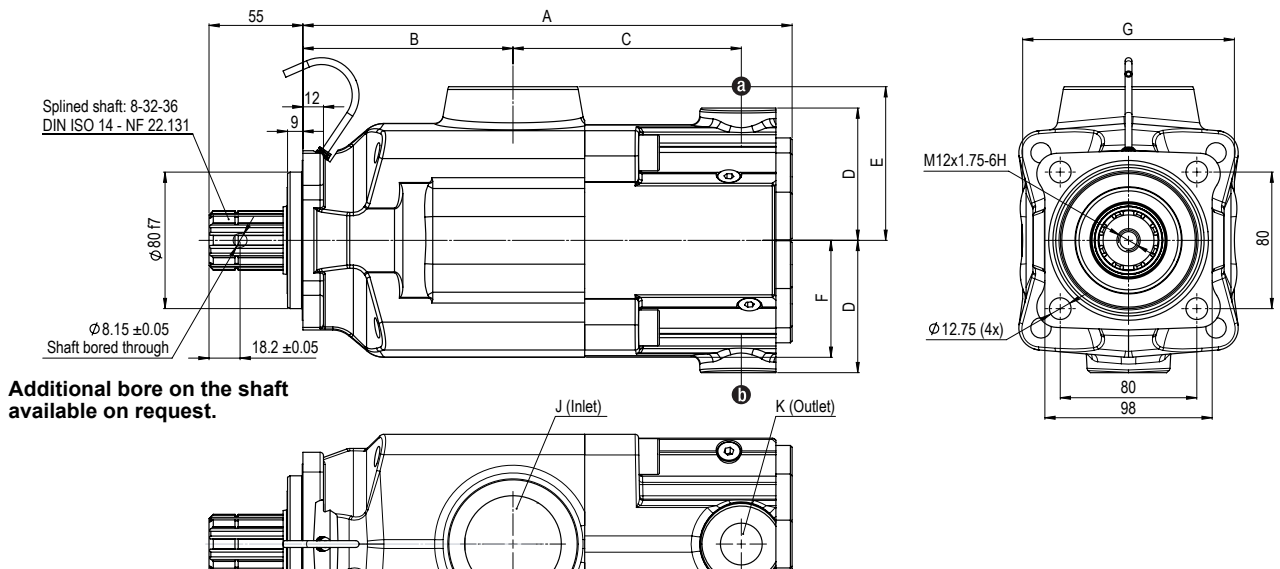

Pump reference	Displac. (cc/rev)		A	B	C	D	E	F	G	J	K	Weight (kg)	Overhang torque (N.m)	
	a	b												
► Single flow														
PA 25	0511510	25	-	261	102	126	47	78	64	107	G 1 1/2"	G 3/4"	15	17
PA 32	0511515	34	-	261	102	126	47	78	64	107	G 1 1/2"	G 3/4"	15	17
PA 40	0511520	43	-	261	102	126	47	78	64	107	G 1 1/2"	G 3/4"	15	17
PA 50	0511525	50	-	261	102	126	47	78	64	107	G 1 1/2"	G 3/4"	15	17
PA 63	0511530	66	-	290	123	138.8	69	90	69	124	G 2"	G 3/4"	23.5	17
PA 80	0511535	82	-	290	123	138.8	69	90	69	124	G 2"	G 3/4"	23.5	31.5
PA 100	0511565	104	-	290	123	138.8	69	90	69	124	G 2"	G 3/4"	23.5	31.5
PA 114	0511570	114	-	290	123	138.8	69	90	69	124	G 2"	G 3/4"	23.5	31.5
► Twin-flow - 2 x 3 pistons														
PAC 25	0511470	26	-	226	94.9	103.3	62	73.2	54	98	G 1 1/2"	G 3/4"	12.5	12.6
PAC 40	0511460	40	-	226	94.9	103.3	62	73.2	54	98	G 1 1/2"	G 3/4"	12.5	12.6
PAC 50	0511465	50	-	226	94.9	103.3	62	73.2	54	98	G 1 1/2"	G 3/4"	12.5	12.6
PAC 65	0511490	65	-	243	102.5	112.8	63	78	65	107	G 1 1/2"	G 3/4"	16	17.6
PAC 80	0511705	78	-	247	102.5	116.3	63	78	65	107	G 1 1/2"	G 3/4"	17	21.3
► Twin-flow - 2 x 5 pistons														
PAD 2 x 32	0511545	32	32	290	123	138.8	69	90	69	124	G 2"	G 3/4"	23.5	31.5
PAD 2 x 40	0511550	39	39	290	123	138.8	69	90	69	124	G 2"	G 3/4"	23.5	31.5
PAD 2 x 50	0511555	52	52	290	123	138.8	69	90	69	124	G 2"	G 3/4"	23.5	31.5
PAD 2 x 57	0511560	57	57	290	123	138.8	69	90	69	124	G 2"	G 3/4"	23.5	31.5
PAD 2 x 75	0516100	75	75	302	126	147.8	72.5	90	72.5	135	G 2"	G 3/4"	26.8	38.7
PAD 75-40	0516810	75	40	302	126	147.8	72.5	90	72.5	135	G 2"	G 3/4"	27.4	38.7
PAC 2 x 25	0511480	25	25	243	102.5	112.8	63	78	65	107	G 1 1/2"	G 3/4"	16	17.6
PAC 2 x 32	0511485	32	32	243	102.5	112.8	63	78	65	107	G 1 1/2"	G 3/4"	16	17.6
PAC 2 x 40	0511710	39	39	247	102.5	116.3	63	78	65	107	G 1 1/2"	G 3/4"	17	21.3
► Twin-flow - 2 x 5 pistons														
PAD 2 x 32	0521240	32	32	287	123	133.8	77.5	90	69	124	G 2"	G 3/4"	24.6	34.4
PAD 2 x 40	0521230	40	40	287	123	133.8	77.5	90	69	124	G 2"	G 3/4"	24.6	34.4
PAD 2 x 55	0521210	55	55	287	123	133.8	77.5	90	69	124	G 2"	G 3/4"	24.6	34.4
PAD 2 x 67	0518270	67	67	287	123	133.8	77.5	90	69	124	G 2"	G 3/4"	24.6	34.4
PAD 55-33	0521250	55	33	287	123	133.8	77.5	90	69	124	G 2"	G 3/4"	24.6	34.4
PAD 67-40	0518290	67	40	287	123	133.8	77.5	90	69	124	G 2"	G 3/4"	24.6	34.4

► Torque absorbed as a function of pump output pressure

Single flow models

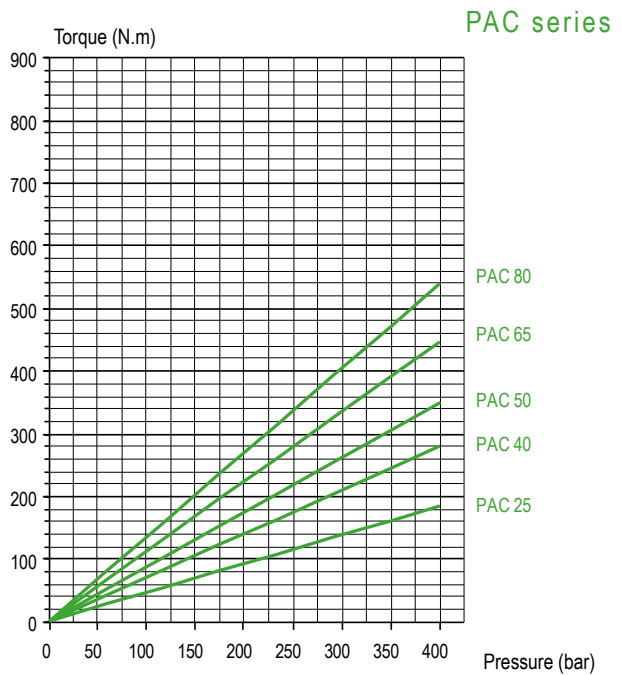
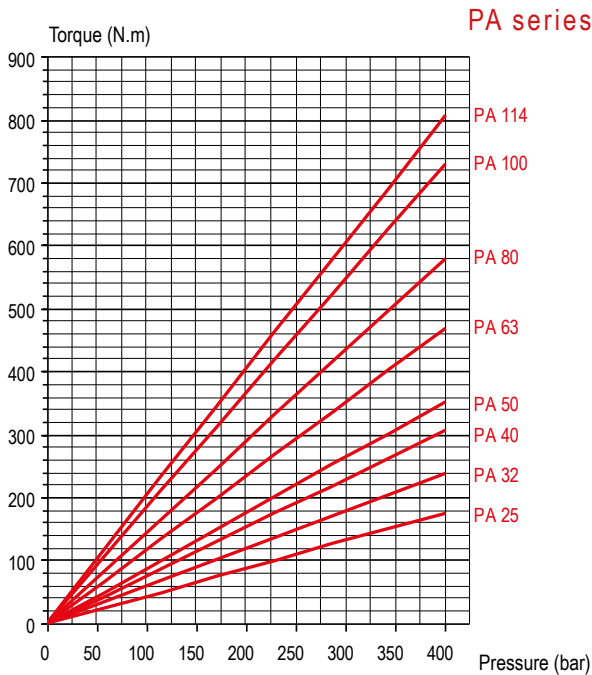

Twin-flow models

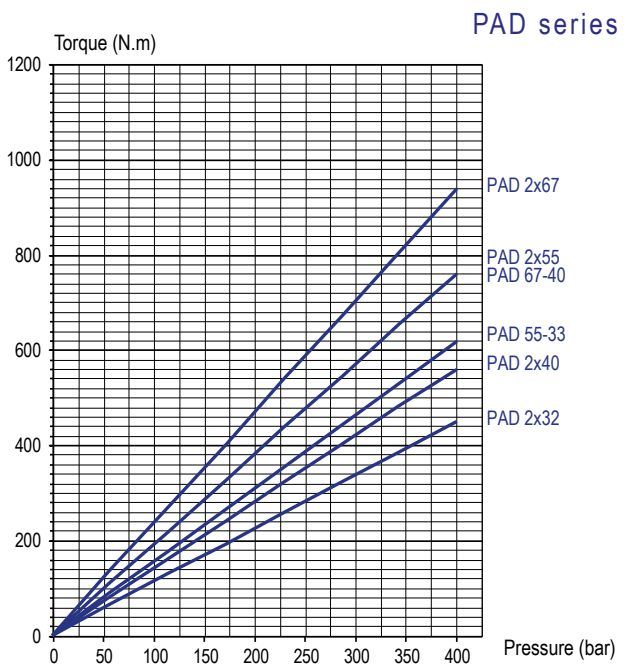
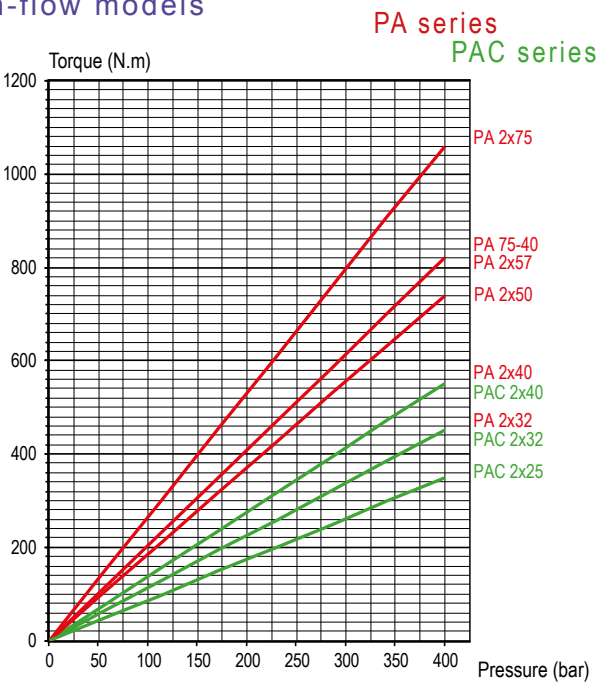

PA - PAC - PAD Series

► Calculation of power to be supplied to the shaft as a function of flow and pressure

$$\mathcal{P} = \frac{\Delta P \times Q}{600}$$

Calculation of torque to determine PTO,
as a function of power and speed

$$C = \frac{\mathcal{P}}{\omega} \times 1000 \quad \text{where} \quad \omega = \frac{\pi N}{30}$$

where:

- \mathcal{P} = theoretical hydraulic power in kW
- C = theoretical torque in N.m
- N = rotating speed in rpm
- ΔP = differential pressure power in bar
- Q = flow in l/min
- ω = angular speed in rad/s



► Flow as a function of rotating speed

Single flow models

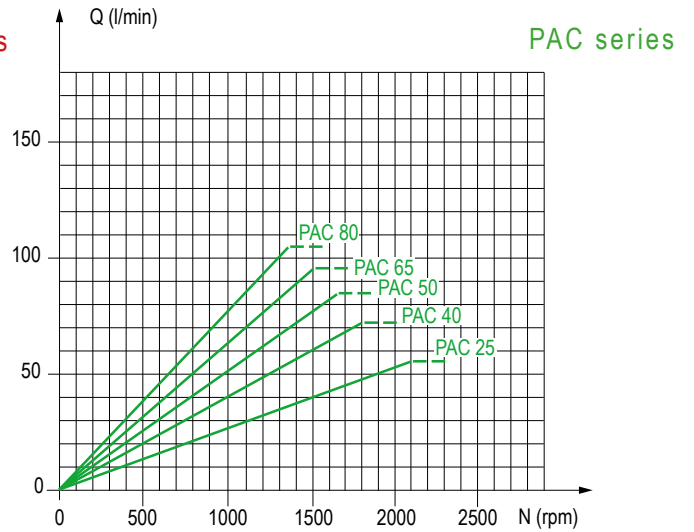
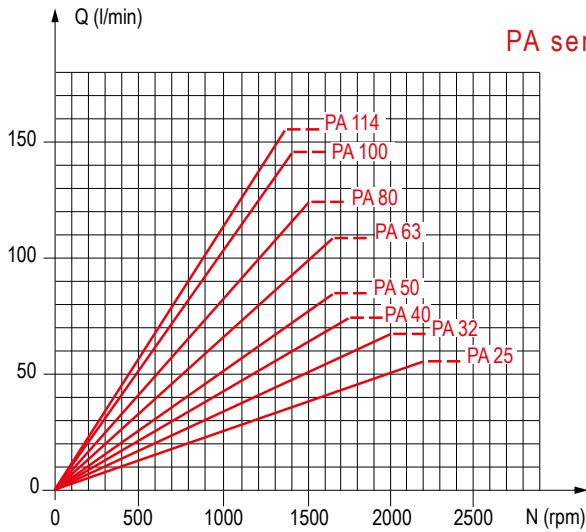

Twin-flow models

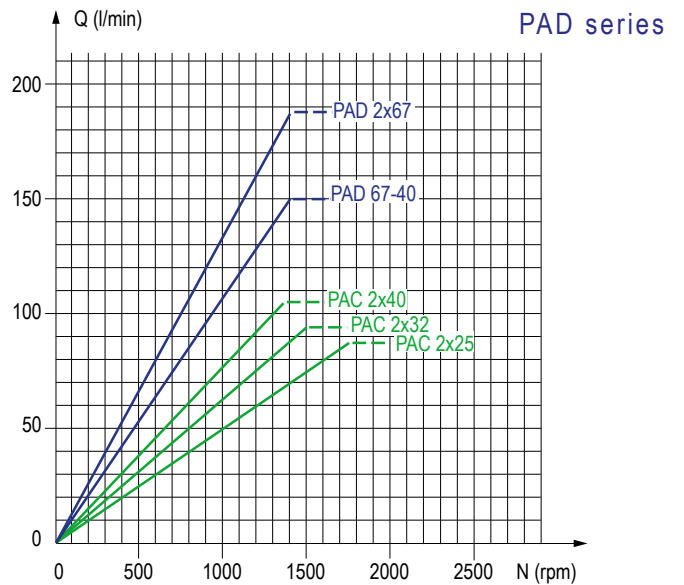
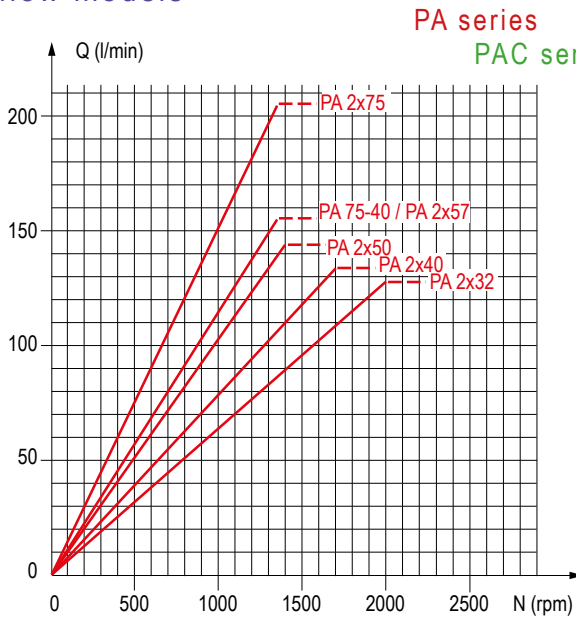

► Volumetric efficiency

These graphs are the results of testwork done in HL R&D laboratory, on a specific test bench, with an ISO 46 fluid at 77°F/25°C (100 cSt), the pump is fitted with a 2" inner diameter HL inlet fitting, and oil level at same height as the pump.

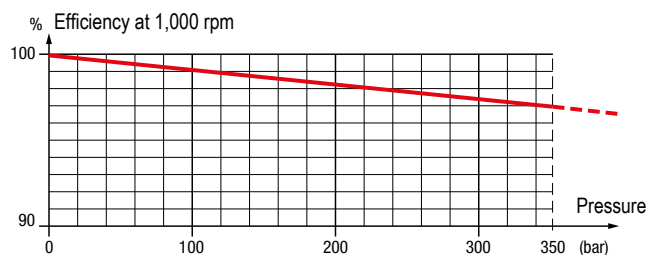

INLET FITTINGS FOR PA | PAC | PAD PUMPS

See recommendations of the hosing dimensions on page 38.

90° elbow fittings, swivel

Reference	A	Ø B	C	D	E	F	Pump types
240131	G 1 1/2"	40	60	17	61	77	PA and PAC
240133	G 1 1/2"	50	60	17	65	82	PA and PAC
240135	G 2"	50	70	17	65	82	PA and PAD

Dimensions in mm.

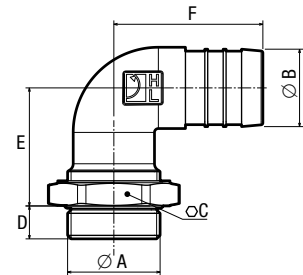

Straight fittings

Reference	A	Ø B	C	D	E	Pump types
240182	G 1 1/2"	40	56	14	54	PA and PAC
240067	G 1 1/2"	50	52	14	66	PA and PAC
240066	G 1 1/2"	60	64	14	69	PA and PAC
240186	G 1 1/2"	63.5	64	14	69	PA and PAC
240183	G 2"	50	66	14	54	PA and PAD
240170	G 2"	60	66	14	72	PA and PAD
240201	G 1 1/2"	76.2	80	14	89	PA and PAC

Dimensions in mm.

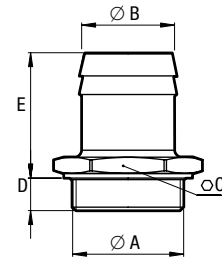

DEFLECTOR TO PROTECT SHAFT SEALS

This deflector ensures the protection of the pump shaft seals. In particular, it protects the pump from projections of dirt from the road in cardan drive installations.

Reference: **DEF 054111**

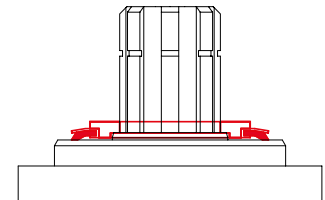

CARDAN PLATE DIN 90

The PLT 056315 cardan plate enables the pump shaft to be connected to a cardan shaft with interface as on drawing on the right.

Note: the maximum admissible torque is limited by the drive shaft.

Reference: **PLT 056315**

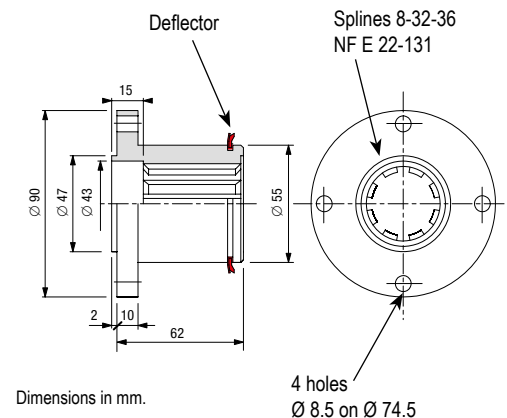

Dimensions in mm.