

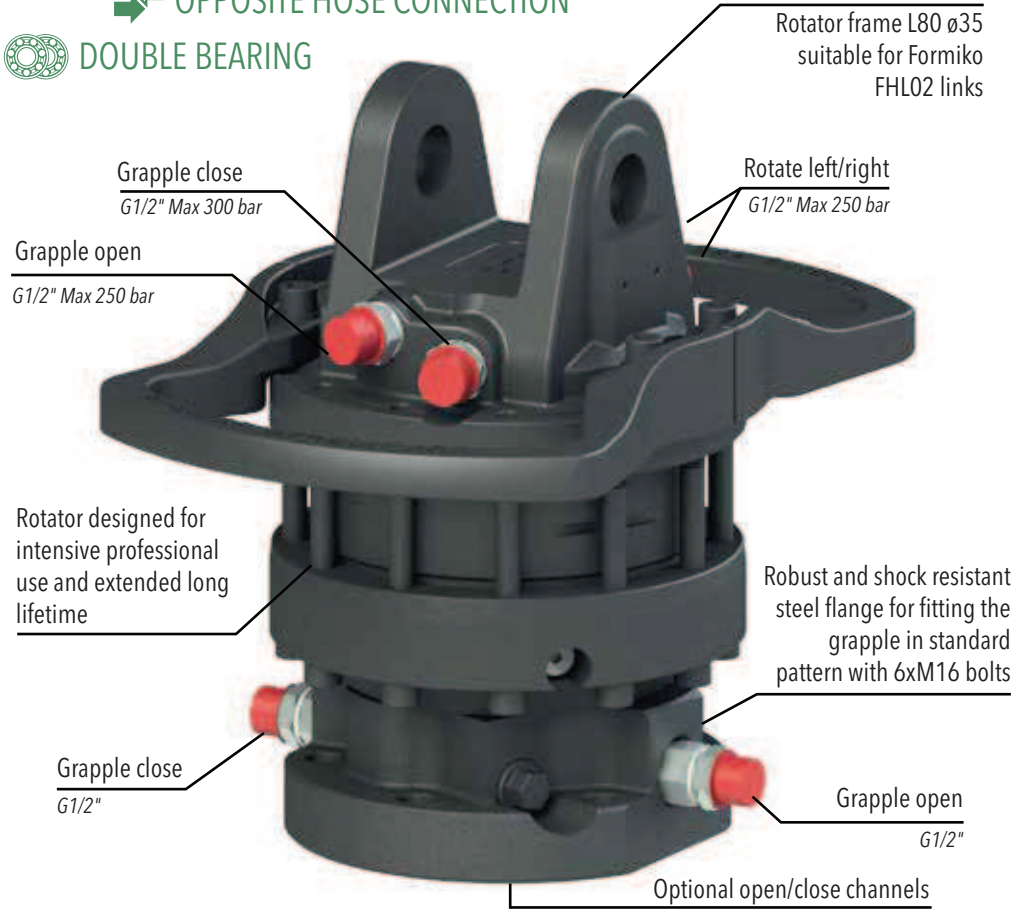

OPPOSITE HOSE CONNECTION

DOUBLE BEARING



100
kN



STATIC LOAD

50
kN



DYNAMIC LOAD

2800
Nm



TORQUE at 25MPa

65
kg



WEIGHT

30
l/min



OILFLOW



FHL02

COMPATIBILITY

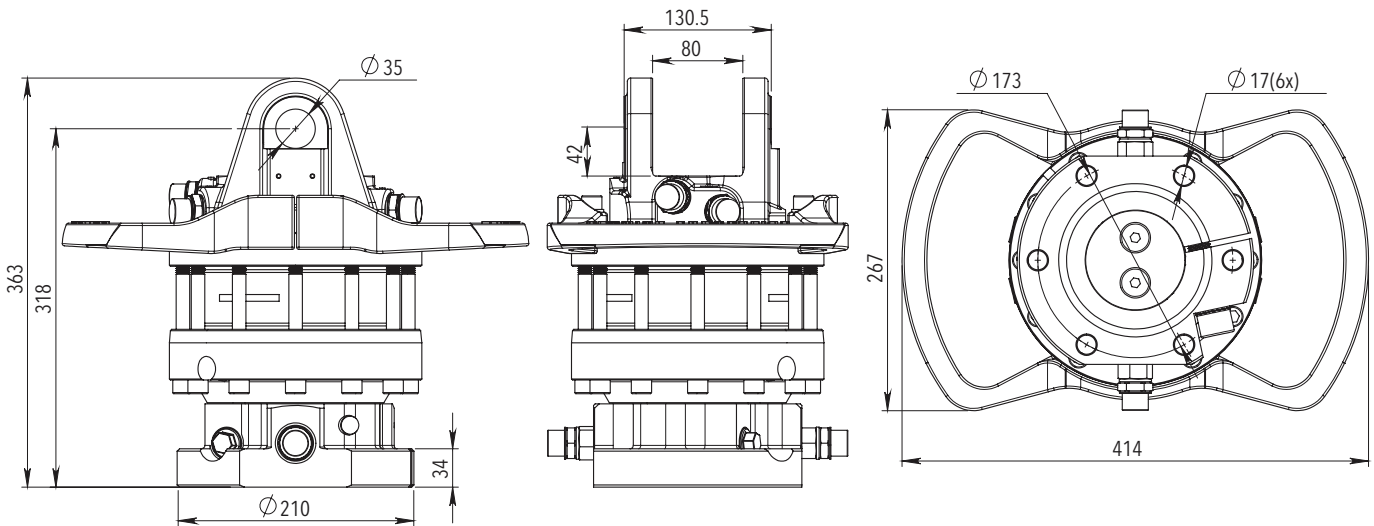

For additional information relating to price levels and technical data, please contact sales@formiko.lv

Formiko Hydraulics Ltd
Dzirciema Str. 119 k-1
Riga LV1055
LATVIA

+371 294 49 552
+371 264 59 383
sales@formiko.lv
www.formiko.lv

Formiko Hydraulics FHR 10 rotators are designed for heavy forestry and general cargo handling to meet high demands for reliability.



FORESTRY



AGRICULTURE CONSTRUCTION



GENERAL CARGO



RECYCLING

